

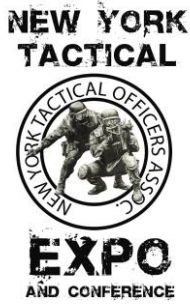

EXHIBITOR KIT 2010

NY TACTICAL EXPO 2010
TURNING STONE RESORT & CASINO
APRIL 27-28, 2010



NEW YORK TACTICAL EXPO 2010

April 27 & 28, 2010

Exhibit Set Up: April 26, 2010

Turning Stone Resort & Casino

Verona, New York

Greetings,

This letter will confirm your participation as an Exhibitor at the New York Tactical Expo 2010 taking place at the Turning Stone Resort & Casino.

On behalf of the New York Tactical Officers Association, thank you for your support.

LOCATION: Turning Stone Resort & Casino, Verona, NY

OFFICIAL SERVICE CONTRACTOR: AEX Convention Services. The Service Manuals (CD) have been sent out to all of our participating exhibitors. If you have not received your CD manual please feel free to call us @ 1-800-323-1927.

EXPO INFORMATION: Phone: 1-800-323-1927 E-mail: nytacticaexpo@comcast.net
Website: www.nyacticaexpo.com or www.nytoa.org

EXPO SET-UP: Monday, April 26th, 2010 8:30 am – 6:00 pm

EXPO OPEN: Tuesday, April 27th, 2010 10:00 am – 5:00 pm
Wednesday, April 28th, 2010 10:00 am – 3:00 pm

HOTEL INFORMATION: Please make your reservations ASAP, as the rooms are filling up quickly.

For Reservations Call: 1-800-771-7711

Turning Stone Resort & Casino
5218 Patrick Road
Verona, NY 13478

\$142 Single/Double
Occupancy per day, plus tax.

Thank You,

Show Management

**NEW YORK
TACTICAL**



EXPO
AND CONFERENCE

EXHIBITOR NAME BADGE REQUESTS

FAX THIS FORM TO: 941-927-5407

Or MAIL to Expo Management:

New York Tactical Expo 2010
P.O. Box 20068, Sarasota, FL 34276-0368

Deadline for receiving all name badge requests is April 16, 2010.

All name badges received after this date will be processed on-site at the Turning Stone Casino & Resort during the Expo.

Name Badge Pick-Up: Name Badges are to be picked up at the Exhibitor Registration Counter which will be located in the Foyer of the Turning Stone Casino & Resort, during Exhibitor set-up and show hours. *They will not be mailed out in advance.*

Memo to: New York Tactical Expo 2010 Management

Fax: 941-927-5407

From: _____
(Company Name)

Booth(s) #: _____ Requested By: _____

Please print Name Badges for the following people who will be at our Exhibit Booth during the New York Tactical Expo '10:

1. _____

2. _____

3. _____

4. _____

5. _____

EXPO PRIZE RAFFLE DRAWINGS

**LOOKING FOR ADDITIONAL EXPOSURE AT THE NEW YORK
TACTICAL EXPO 2010????**

New York Tactical Expo 2010 Exhibitors are encouraged to offer product samples directly from your Exhibit Space as a way to market your company or organization.

In addition, every hour, Expo Attendees will have a chance to win a special prize. *Use this opportunity to bring attention to your company.*

Companies donating goods, products, or special services will be listed in Expo Directory.

Please mail this form back to Expo Manager

New York Tactical Expo 2010

P.O. Box 20068

Sarasota, FL 34276-0368

OR

Fax to: (941) 927-5407

NEW YORK
TACTICAL



EXPO
AND CONFERENCE

Company Name: _____

Booth(s)#: _____

Your Name: _____

Prize(s) to be donated:

WEAPONS REGISTRATION FORM

IMPORTANT: EXPO MANAGEMENT MUST BE NOTIFIED NO LATER THAN APRIL 16, 2010 IF YOU WILL BE EXHIBITING OR DISPLAYING FIREARMS OR WEAPONS AT YOUR EXHIBIT BOOTH LOCATION.

LIST THE FIREARMS/WEAPONS THAT YOU ARE DISPLAYING AT YOUR BOOTH(S) BELOW:

Company Name: _____

Booth(s) #: _____

Your Name: _____

Item(s):

Notification Deadline: April 16, 2010

Mail To:
Expo Management
New York Tactical Expo '10
P.O. Box 20068
Sarasota, FL 34276

or

Fax To: (941)-927-5407

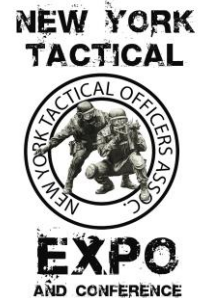

This is a requirement to Exhibit. You can list addition firearms/weapons on a separate page, if needed. A security lock-up room will be provided at no charge at the Expo, during non-show hours.

DIRECTIONS TO TURNING STONE RESORT & CONVENTION CENTER

Location: 5218 Patrick Road, Verona, New York 13478

NOTE: The Turning Stone Resort & Convention Center can pre-arrange transportation service to and from the Syracuse Hancock International Airport on a scheduled timeframe. Costs range from \$75 for Limo Service to \$100 for Shuttle Bus Service, per trip.

FROM THE SYRACUSE HANCOCK AIRPORT:

- Take I-90 East (NYS Thruway) to Exit 33 (Verona)
- Go through the tollbooth and travel straight to the next stoplight.
- Take a left onto 365 and the next left into the resort.

FROM THE NORTH:

- Take Route I-81 South
- Take I-481 South
- Take I-90 East (NYS Thruway) to Exit 33 (Verona)
- Go through the tollbooth and travel straight to the next stoplight.
- Take a left onto 365 and the next left into the resort.

FROM THE SOUTH:

- Take I-81 North to Exit 16A
- Take I-481 North to Exit 6
- Take I-90 East (NYS Thruway) to Exit 33 (Verona)
- Go through the tollbooth and travel straight to the next stoplight.
- Take a left onto 365 and the next left into the resort.

FROM THE EAST:

- Take I-90 West (NYS Thruway) to Exit 33 (Verona).
- Go through the tollbooth and travel straight to the next stoplight.
- Take a left onto 365 and the next left into the resort.

FROM NYC:

- Take I-87 North (NYS Thruway) to I-90 West (NYS Thruway) to Exit 33 (Verona).
- Go through the tollbooth and travel straight to the next stoplight.
- Take a left onto 365 and the next left into the resort.

NOTE: In the Albany Area, I-87 becomes I-90. Make sure you stay on the Thruway (Toll Road) and do not exit in the Albany Area. If you are on I-87 Northway, get back to I-90 going west.



Turning Stone
resort • casino

Audio Visual Order Form

Please return to Turning Stone Resort & Casino
5218 Patrick Road
Verona, NY 13478
General Sales Office (315) 361-7824
Fax (315) 361-8500

Name of Event: _____ Date(s) of Event: _____ Booth #: _____

On-site contact: _____ Firm Name: _____

Address: _____ Phone #: _____ Fax: _____

Payment: Check (Payable to Oneida Indian Nation) / Credit Card (VISA, MasterCard, Amex, Discover)

Name on Card: _____ Credit Card Number: _____ Exp: _____

Authorized by: _____ Title: _____ Date: _____

**PAYMENT MUST ACCOMPANY ORDER
ALL ITEMS SUBJECT TO AVAILABILTIY
NO GUARANTEED SERVICE FOR ON SITE ORDERS
ON SITE ORDERS WILL INCUR A 15% SURCHARGE**

ALL ITEMS ARE SUBJECT TO 19% SERVICE CHARGE AND 5% SALES TAX

OTHER ITEMS AVAILABLE UPON REQUEST – PLEASE CONTACT YOUR CATERING/CONVENTION COORDINATOR

Item	Quantity	Price per day	# of Days	Total
Small Group Projector (25 people or less)		\$250.00		
27" color TV monitor (with skirted cart)		\$75.00		
27" color monitor with VCR/DVD combo		\$125.00		
43" plasma screen (with floor stand)		\$400.00		
DVD/VCR combo player		\$50.00		
6' x 6' tripod screen		\$30.00		
8' x 8' tripod screen		\$40.00		
Flipchart & Markers		\$20.00		
Poster Easel		\$10.00		
AV cart/skirt		\$10.00		
Power Strip		\$5.00		
Extension Cord (10' or 50')		\$5.00		
Wired Microphone		\$25.00		
Wireless Microphone		\$75.00		
CD or cassette player		\$50.00		
Public Address Portable Sound System		\$105.00		
Patch into house sound		\$30.00		
Network cable		\$10.00		



Turning Stone
resort • casino

Internet Service Order Form

Please return to Turning Stone Resort & Casino
5218 Patrick Road
Verona, NY 13478
General Sales Office (315) 361-7824
Fax (315) 361-8500

Name of Event: _____ Date(s) of Event: _____ Booth #: _____

On-site contact: _____ Firm Name: _____

Address: _____ Phone #: _____ Fax: _____

Payment: Check (Payable to Oneida Indian Nation) / Credit Card (VISA, MasterCard, Amex, Discover)

Name on Card: _____ Credit Card Number: _____ Exp: _____

Authorized by: _____ Title: _____ Date: _____

**PAYMENT MUST ACCOMPANY ORDER
ALL ITEMS SUBJECT TO AVAILABILTIY
NO GUARANTEED SERVICE FOR ON SITE ORDERS
ON SITE ORDERS WILL INCUR A 15% SURCHARGE
ALL ITEMS ARE SUBJECT TO 19% SERVICE CHARGE AND 5% SALES TAX
OTHER ITEMS AVAILABLE UPON REQUEST – PLEASE CONTACT YOUR CATERING/CONVENTION COORDINATOR**

Item	Quantity	Price per day	# of Days	Total
High Speed Wired Connection		\$50.00		
Additional Connection at the same location		\$25.00		
Network Cable		\$10.00		

Rules and Regulations

1. Turning Stone Resort and Casino is the exclusive provider of telecommunications throughout the facility.
2. Incomplete telecommunications requirements may delay processing and labor charges will be added in the event of changes made after initial installation.
3. Credit will not be given for service installed and not used.
4. The Customer will be fully responsible for the protection and safekeeping of the Internet connection apparatus as well as safekeeping of their personal or company computer equipment.
5. Only Turning Stone Resort and Casino personnel are authorized to modify system wiring and cable.
6. Turning Stone Resort and Casino are not responsible for any level fluctuations or band-width failure due to the local Internet Service Provider (ISP) company conditions and or the local telephone company.
7. All equipment must comply with FCC regulations.
8. Prices are based on current rates and may change without notice.
9. Rate quotes or other inquiries for Internet Service, telephone service and other special needs should be directed to the Turning Stone Resort and Casino Catering/Convention Coordinator.
10. Turning Stone Resort and Casino will provide DSL through one 10-Base T drop to your booth (RJ-45 plug) and one IP address for a single computer in your booth. You need to provide each computer(s) with a 10-Base T or 10/100 Ethernet network card and with TCP/IP installed and access to the properties. Sharing your connection with another booth or company is prohibited. Additional fees will be charged if you need Turning Stone Resort and Casino to provide wiring between your computers and hub or if your company needs network access at more than one location.



Turning Stone
resort • casino

Telephone Service Order Form

Please return to Turning Stone Resort & Casino
5218 Patrick Road
Verona, NY 13478
General Sales Office (315) 361-7824
Fax (315) 361-8500

Name of Event: _____ Date(s) of Event: _____ Booth #: _____

On-site contact: _____ Firm Name: _____

Address: _____ Phone #: _____ Fax: _____

Payment: Check (Payable to Oneida Indian Nation) / Credit Card (VISA, MasterCard, Amex, Discover)

Name on Card: _____ Credit Card Number: _____ Exp: _____

Authorized by: _____ Title: _____ Date: _____

**PAYMENT MUST ACCOMPANY ORDER
ALL ITEMS SUBJECT TO AVAILABILTIY
NO GUARANTEED SERVICE FOR ON SITE ORDERS
ON SITE ORDERS WILL INCUR A 15% SURCHARGE
ALL ITEMS ARE SUBJECT TO 19% SERVICE CHARGE AND 5% SALES TAX
OTHER ITEMS AVAILABLE UPON REQUEST – PLEASE CONTACT YOUR CATERING/CONVENTION COORDINATOR**

Item	Quantity	Price per day	# of Days	Total
Analog Phone Line (used for modems)		\$150.00		
Direct Inward Dial Phone Line (allows direct access from outside independent number)		\$150.00		
House Phone (in-house access only)		\$50.00		
Speaker Phone (phone line not included)		\$90.00		

Rules and Regulations

- Turning Stone Resort and Casino is the exclusive provider of telecommunications throughout the facility.
- Incomplete telecommunications requirements may delay processing and labor charges will be added in the event of changes made after initial installation.
- Credit will not be given for service installed and not used.
- The Customer will be fully responsible for the protection and safekeeping of the telephone sets.
- Only Turning Stone Resort and Casino personnel are authorized to modify system wiring and cable.
- Turning Stone Resort and Casino are not responsible for any level fluctuations or band-width failure due to the local Internet Service Provider (ISP) company conditions and or the local telephone company.
- All equipment must comply with FCC regulations.
- Prices are based on current rates and may change without notice.
- Rate quotes or other inquiries for Internet Service, telephone service and other special needs should be directed to the Turning Stone Resort and Casino Catering/Convention Coordinator.
- In addition to basic telephone charges, exhibitors will be charged for local and long distance calls at prevailing rates.



Turning Stone
resort • casino

Forklift & Genie Lift Order Form

Please return to Turning Stone Resort & Casino
5218 Patrick Road
Verona, NY 13478
General Sales Office (315) 361-7824
Fax (315) 361-8500

Name of Event: _____ Date(s) of Event: _____ Booth #: _____

On-site contact: _____ Firm Name: _____

Address: _____ Phone #: _____ Fax: _____

Payment: Check (Payable to Oneida Indian Nation) / Credit Card (VISA, MasterCard, Amex, Discover)

Name on Card: _____ Credit Card Number: _____ Exp: _____

Authorized by: _____ Title: _____ Date: _____

**PAYMENT MUST ACCOMPANY ORDER
ALL ITEMS SUBJECT TO AVAILABILTIY
NO GUARANTEED SERVICE FOR ON SITE ORDERS
ON SITE ORDERS WILL INCUR A 15% SURCHARGE
ALL ITEMS ARE SUBJECT TO 19% SERVICE CHARGE AND 5% SALES TAX
OTHER ITEMS AVAILABLE UPON REQUEST – PLEASE CONTACT YOUR CATERING/CONVENTION COORDINATOR**

Item	Quantity	Price per day	# of Days	Total
Forklift with operator per hour (4 hr minimum)		\$60.00/hr		
Genie lift or Scissor Lift with operator per hour (4 hr minimum)		\$60.00/hr		
Boomlift with operator per hour (4 hr minimum)		\$75.00/hr		
Stagehand Labor (4 hr minimum)		\$17.00/hr		
Technician Labor (4 hr minimum)		\$25.00/hr		
Rigger labor (4 hr minimum)		\$28.00/hr		

Estimated time needed (# of hours): _____

Start Time: _____

Finish Time: _____
(please indicate AM or PM)

Special Orders/Memos/Instructions: _____





Notice to Exhibitors

At Turning Stone Resort & Casino there is no smoking in any of the convention areas or public foyers. There are designated smoking areas on the Casino floor.

Decorations, signs, banners, etc.....may not be taped, nailed, tacked, stapled, or otherwise fastened to ceilings, walls, painted surfaces, or any space within Turning Stone Resort & Casino.

No holes may be drilled, cored, or punched in any building within Turning Stone Resort.

No adhesive backed (stick-on) decals or similar items may be distributed in any building within Turning Stone Resort.

Any item hung 8' or more overhead must be hung by Turning Stone riggers and at the expense of the exhibitor.

If you require disposal of any cardboard boxes, all boxes must be broken down. Please leave broken down boxes in the aisle way and Turning Stone Resort personnel will have it removed.

Exhibitor sponsoring organizations and/or exhibitors may not distribute sample food/or beverage products except upon written authorization from Turning Stone Resort's Director of Food and Beverage.

The distribution and/or sale of alcoholic beverages is strictly prohibited. Turning Stone Resort reserves the right to remove any alcoholic beverages.

Parking in the loading dock and service drives, except for loading and unloading, is prohibited. Violators will be towed at their expense and risk.

All freight and exhibit materials must enter the building through designated loading docks. In no case should passenger elevators, escalators, or public lobbies be used for freight and/or exhibitor load in or load out.

Turning Stone Resort does not accept deliveries of freight, packages or cartons for any customer or exhibitor. Please arrange for drayage with an outside contractor. Shipments arriving at Turning Stone Resort will be refused.

Small mail packages may be received the day prior to the event. When shipping packages to Turning Stone Resort be sure to include your name, your company name, booth number and event location, your name and date of event.

Prior to the completion of the event, please schedule return shipments with your own freight company. Please completely tape and label all boxes and arrange removal by the end of the load-out period. Nothing may be left in the facility and Turning Stone Resort takes no responsibility for items left following an event. Materials left at Turning Stone Resort after the show closes will be considered trash and will be disposed of accordingly.

All fire and safety building regulations must be strictly followed. Particular attention should be paid to the prohibition against propane, acetylene, and other flammable materials. Questions may be directed to your Catering/Convention Coordinator. Exhibitors are responsible for showing proof of flame retardant materials. Please see enclosed TSRC Fire & Safety Guidelines.

If you have questions, please feel free to contact the Catering/Convention Coordinator assigned to your event at Turning Stone Resort by calling the main phone number at 315-361-7824.

Show Name: NY TACTICAL EXPO 2010

Show Dates: APRIL 27-28, 2010

Deadline Date To Receive Discounted Rates: APRIL 12, 2010

EXHIBITOR MOVE-IN

MONDAY	APRIL 26, 2010	8:30 AM - 5:00 PM
TUESDAY	APRIL 27, 2010	7:00 AM - 9:30 AM

SHOW HOURS

TUESDAY	APRIL 27, 2010	10:00 AM - 5:00 PM
WEDNESDAY	APRIL 28, 2010	10:00 AM - 3:00 PM

EXHIBITOR MOVE-OUT

WEDNESDAY	APRIL 28, 2010	3:00 PM - 11:00 PM
-----------	----------------	--------------------

Move-Out Note: All carriers must check in no later than 6:00 PM on WEDNESDAY, APRIL 28, 2010 or freight will be shipped C.O.D. via LibertyCFS c/o Roadway Express.

BOOTH EQUIPMENT:

Each 8' X 10' booth space will be provided with an 8' BLACK, WHITE & GOLD background drape, 42" BLACK side divider drapes, 1- 6' BLACK draped table, 2 side chairs, a wastebasket and booth ID sign.

CARPET COLOR:

The booth area and aisles are NOT carpeted. You may carpet your booth area in any offered color, please see the enclosed Carpet Rental Order Form.

ADVANCE WAREHOUSE:

NY TACTICAL EXPO 2010

AEX Convention Services

Exhibiting Company Name / Company Booth #

c/o Warehouse Manager

6990 Northern Blvd., East Syracuse, NY 13057

Materials should be shipped to ARRIVE at our warehouse **NO LATER THAN** APRIL 19, 2010. Any shipments received more than 30-days prior to the Move-In will incur additional charges. *Freight that arrives after the show opens will be charged direct rate plus an additional \$7.00 per cwt.*

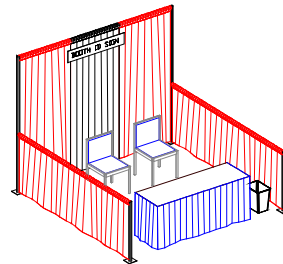

DIRECTLY TO FACILITY:

NY TACTICAL EXPO 2010

TURNING STONE RESORT & CASINO

Exhibiting Company Name / Company Booth #

c/o AEX Convention Services

5218 Patrick Road, Verona, NY 13478

Materials should be shipped to ARRIVE at the facility on April 26, 2010, between 8:30 AM - 5:00 PM and April 27, 2010, between 7:00 AM - 9:30 AM ONLY.

ASSISTANCE: If you have any questions or would like assistance, please call our office at (609) 272-1600.



Show Name: NY TACTICAL EXPO 2010

Show Dates: APRIL 27-28, 2010

Deadline Date To Receive Discounted Rates: APRIL 12, 2010

AEX CONVENTION SERVICES

Administrative Offices
3089 English Creek Ave.
Egg Harbor Twp., NJ 08234
Phone: (609) 272-1600 Fax: (609) 272-1680

ADVANCE WAREHOUSE

AEX Convention Services
c/o Warehouse Manager
6990 Northern Blvd.
East Syracuse, NY 13057
Phone: (609) 272-1600
Fax: (609) 272-1680

**AIR , GROUND & VAN LINE
FREIGHT SERVICES**

LibertyCFS, Inc.
Phone: (905) 338-3993 Fax: (905) 338-1092

**AUDIO, VISUAL COMPUTER
RENTAL SERVICES**

Turning Stone Resort & Casino
Phone: (315) 361-7824 Fax: (315) 361-8500

**TELEPHONE SERVICE
INTERNET SERVICE**

Turning Stone Resort & Casino
Phone: (315) 361-7824 Fax: (315) 361-8500

SHOW MANAGEMENT

Sitework Associates, Inc.
PO Box 20068
Sarasota, Florida 34276
Phone: (941) 927-5400
Fax: (941) 927-5407

SPECIALTY FURNITURE SERVICE

AEX Convention Services
Phone: (609) 272-1600 Fax: (609) 272-1680

ELECTRICAL SERVICE

Expo Management
P.O. Box 20068
Sarasota, FL 34276
Phone: (941) 927-5400
Fax: (941) 927-5407





**LIMITS & LIABILITIES AND TERMS AND CONDITIONS
BY USING OUR SERVICES OR SIGNING THE AGREEMENT TO TERMS AND CONDITIONS, YOU AND YOUR
COMPANY AGREE TO THE FOLLOWING**

DRAYAGE/FREIGHT RATES APPLY to each pound with a minimum (see front for actual minimum) and are based on the actual or estimated INBOUND weight. No allowance will be made for during the event. Each shipment is considered separately. NO cumulative weights will be allowed on minimums, split shipments, etc.

SHIPMENTS OF EQUIPMENT REQUIRING SPECIAL HANDLING at the facilities will be subject to a surcharge as indicated on the freight rate schedule. This classification shall be applied to, but not limited to, van shipments or shipments which are packed in such a manner as to require unloading by hand (e.g., loose display parts, uncrated equipment, etc.) Material will be unloaded from vans, exhibitor's truck, or trucks of others at the facility, delivered to the Exhibitor's booth, picked up at the close of the show, moved to the loading area and reloaded. The Exhibitor must provide written and accurate weight information on each shipment. Shipments received without Certified Weight Tickets or Bills of Lading, such as UPS or U.S. Mail, will be delivered to the booth without guarantee of piece count or condition. No liability will be assumed for such shipments.

SPECIAL SERVICES AND RATES - Steel banding for the packing of displays and equipment is available at the AEX Convention Services service desk for \$2.00 per linear ft. plus labor at prevailing rates. Forklifts and drivers are available for spotting equipment in the booth at prevailing rates for equipment and labor. Shrink-Wrap is available at a flat rate of \$45.00 per 4'x4'x4' pallet, thereafter pro-rata.

EMPTY CONTAINER STORAGE - Properly labeled empty containers of freight handled by AEX Convention Services will be removed and returned to the booth; "empty" labels will be available at the service desk. Affixing labels is the sole responsibility of the Exhibitor or representative who must remove or obliterate all old labels. AEX Convention Services assumes no responsibility for removal of containers with old empty storage labels or without AEX Convention Services labels, improper information on empty labels or valuables stored in containers with empty labels. Handling of empty containers of freight not brought in by AEX Convention Services will be charged \$15.00 per box or crate each way.

OUTBOUND SHIPPING INSTRUCTIONS should be given to AEX Convention Services during the event or immediately after its close. All bills of lading and shipping instructions covering outbound shipments will be checked at the time of actual loading and corrections made where discrepancies exist. Freight remaining on the exhibit floor without proper instructions for disposition will be removed by AEX Convention Services and shipped with the information available at the time using a carrier of AEX Convention Service's choice or brought to AEX's warehouse storage and handling will be charged. AEX Convention Services will not be liable for shipping errors subsequent to the event unless it has agreed to specific written instructions has failed to honor them. The condition, count, and contents of the materials found in the booth at the time of actual removal will be final and binding and the right is reserved to alter exhibitor's bill of lading to reflect actual condition, count, and content found.

LIMITATIONS OF LIABILITY - AEX Convention Services IS NOT responsible for damage to materials improperly packed, concealed damage, loss or theft of Exhibitors' material after same has been delivered to your booth, or before materials have been picked up for loading out of the booth. AEX Convention Services makes no warranties or claims except as may be set forth in these terms and conditions. No oral modifications may be made to these terms. Regardless of your claim, AEX Convention Service's liability with respect to your freight or any damage whatsoever, is limited to \$.10 per pound/per article, with a maximum of \$50.00 per item, and a maximum of \$1,000.00 per shipment, even in the event of AEX Convention Service's negligence. AEX's liability for any damages whatsoever when you hire us for supervised installation/dismantle is limited to the actual cost for supervision.

EXHIBIT LOSS OR DISAPPEARANCE - AEX Convention Services and its subcontractors ARE NOT responsible for loss or disappearance of Exhibitor's material after such material has been delivered to the Exhibitor's booth. Relative to inbound shipments, there may be a lapse of time between the delivery of shipment(s) to the applicable booth by AEX Convention Services or its subcontractors, and the arrival of Exhibitor's representative at the booth. During such time the shipment(s) will be left unattended in the booth. AEX Convention Services or its subcontractors shall not be responsible for any loss or damage that may occur during such a period.

Similarly, AEX Convention Services and its subcontractors ARE NOT responsible for loss or disappearance of Exhibitor's material before Exhibitor's material is picked up from the Exhibitor's booth for loading after the exhibition. All bills-of-lading covering outgoing shipment that are given to AEX Convention Services by the Exhibitor will be checked at the time of pick-up from the booth, and corrections will be made at such time if discrepancies exist. Relative to outgoing shipments, it is possible that there will be a lapse of time between the completion of the packing and the pick up material from the booths for loading onto a damage that may occur during such period. AEX Convention Services and its subcontractors are not responsible for any loss or damage that may occur during such period. AEX Convention Services and its subcontractors will adjust the quantities of items on any bill-of-lading submitted to AEX Convention Services or its subcontractors to conform to the actual count of such items in the booth at the time of pick-up and shipment.

DISPUTES - In the event of any dispute between an Exhibitor and AEX Convention Services relative to any loss or damage to such Exhibitor's material, such Exhibitor shall not be entitled to and shall not withhold payment of any amount due to AEX Convention Services for services or rentals provided as any offset against the amount of any alleged loss or damage. Instead, such Exhibitor shall pay AEX Convention Services for any rental or services and Exhibitor may pursue any claim against AEX Convention Services independently. No claims for loss or damage will be considered until payment in full for all services performed by AEX Convention Services has been received.

INSURANCE - Exhibitors agree to carry all-risk floater insurance covering their material against damage, loss, theft and all hazards which covers from the time shipment is made prior to show until shipments are returned to Exhibitor after the show.

We require full payment with order for rentals, service, tax and anticipated freight. This Form, with your credit card information for payment of advance and show site orders, must be completed, mailed or faxed to AEX Convention Services in order for us to provide any rentals or services. Full payment must accompany your order to qualify for the discounted rates. A \$25.00 surcharge will be added to your account if any credit charges are denied or if any checks are returned. Unpaid account will accrue a service charge of 1.5% per month. Exhibitor agrees to be responsible for all fees connected with the collection of its accounts.



CARPET RENTAL ORDER FORM

Please Mail or Fax Completed Form to AEX Convention Services:
 3089 English Creek Ave., Egg Harbor Township, NJ 08234
 Fax: (609) 272-1680 • Phone: (609) 272-1600

Show Name: NY TACTICAL EXPO 2010

Show Dates: APRIL 27-28, 2010

Deadline Date To Receive Discounted Rates: APRIL 12, 2010

STANDARD BOOTH CARPET (Standard booth carpet is not available for Island Booths. Please see the Cut & Lay carpet below.)

Description	Discount	Standard	Total
9' x 10'	\$99.00	\$138.50	\$ _____
9' x 20'	\$198.00	\$277.00	\$ _____
9' x 30'	\$297.00	\$415.50	\$ _____
9' x 40'	\$396.00	\$554.00	\$ _____

Please select color:

- Black Gray Burgundy
 Teal Purple Green
 Blue Red Lime Green

Over 9' x 40' available pro rata.

This carpet is not designed to cover complete booth areas since the rental cost does not include seaming and the carpets are not guaranteed to be a color match. If complete exhibit area carpet is desired, see cut & lay section below.

CUT & LAY CARPET (100 sq. ft. Minimum Order)

Complete Area Size: _____ Ft. x _____ Ft. x _____ Sq. Ft. @

Discount	Standard	Total
\$2.00/sq.ft.	\$3.00/sq.ft.	\$ _____

Please select color:

- Black Gray Burgundy
 Teal Purple Green
 Blue Red Lime Green

DECORATIONS PLUSH CARPET (Subject to availability)

Complete Area Size: _____ Ft. x _____ Ft. x _____ Sq. Ft. @

Description	Discount	Standard	Total
34 oz.	\$5.50/sq.ft.	NA	\$ _____
50 oz.	\$6.50/sq.ft.	NA	\$ _____

Please select color:

- Dusty Rose Light Teal Toast
 Ivory Cream Sandstone
 Baby Blue Sky Blue Navy
 Misty Gray Silver Mist Gun Metal
 Cherry Red Burgundy
 Ebony Forest Green

Order must be received at least four weeks prior to the show.

Custom carpet is a luxurious 34 oz. Or 50 oz. Carpet available in assorted decorator colors.

Swatches will be sent to you upon your request. Minimum order for decorators plush carpet is 200 sq. ft.

PADDING-PLASTIC COVERING-TAPE

Carpet Padding:

Ft. x _____ Ft. = _____ Sq. Ft. @ (Discount \$1.00/sq.ft.)/(Standard \$1.75/sq.ft.) = \$ _____

Visqueen Covering:

Ft. x _____ Ft. = _____ Sq. Ft. @ (Discount \$0.50/sq.ft.)/(Standard \$0.75/sq.ft.) = \$ _____

Additional Carpet Tape: _____ qty. roll(s) @ \$18.50 = \$ _____

(All prices include installation and removal) **SUBTOTAL CARPET RENTAL ORDER: \$ _____**

YES, I have completed and enclosed the Authorization and Agreement to Terms and Conditions Form and I understand that all orders are subject to New York State Sales tax 8.125%.

Company Name: _____ **Booth#:** _____



FURNITURE RENTAL ORDER FORM

Please Mail or Fax Completed Form to AEX Convention Services:
 3089 English Creek Ave., Egg Harbor Township, NJ 08234
 Fax: (609) 272-1680 • Phone: (609) 272-1600

Show Name: NY TACTICAL EXPO 2010

Show Dates: APRIL 27-28, 2010

Deadline Date To Receive Discounted Rates: APRIL 12, 2010

FURNITURE

Description	Discount	Standard	Qty.	Total
Plastic Side Chair	\$35.50	\$43.50	_____	_____
Padded Arm Chair	\$43.50	\$54.50	_____	_____
Deluxe Padded Arm Chair	\$85.25	\$119.00	_____	_____
Padded Counter Stool	\$46.50	\$57.75	_____	_____
Cocktail Table 18" H	\$43.50	\$54.25	_____	_____
Cocktail Table 30" H	\$52.50	\$65.25	_____	_____
Cocktail Table 42" H	\$63.25	\$78.50	_____	_____
Literature Rack	\$242.25	\$339.25	_____	_____
Wastebasket	\$13.00	\$16.25	_____	_____
Easel	\$26.50	\$33.00	_____	_____
Chrome Sign Frame (22" x 28")	\$45.50	\$55.50	_____	_____
Waterfall Bag Rack	\$34.00	\$40.75	_____	_____
Chrome Stanchion	\$37.50	\$46.00	_____	_____
Chrome Bag Holder	\$68.00	\$95.25	_____	_____
Chrome Clothes Tree	\$31.50	\$38.50	_____	_____
White/Silver Plastic Chain(/ft.)	\$7.25	\$10.00	_____	_____
Crossbar	\$19.25	\$27.00	_____	_____
Upright with Base	\$23.00	\$32.25	_____	_____
Security Cage	\$265.25	\$371.50	_____	_____

DISPLAY TABLES (Price includes top covered with white plastic and 3 sides draped)

Description	Discount	Standard	Qty.	Total
4' L x 24" W x 30" H	\$70.25	\$87.50	_____	_____
4' L x 24" W x 42" H	\$92.75	\$112.25	_____	_____
6' L x 24" W x 30" H	\$83.25	\$103.75	_____	_____
6' L x 30" W x 30" H	\$100.00	\$124.75	_____	_____
6' L x 24" W x 42" H	\$101.75	\$127.25	_____	_____
6' L x 30" W x 42" H	\$122.25	\$152.75	_____	_____
8' L x 24" W x 30" H	\$97.50	\$121.25	_____	_____
8' L x 30" W x 30" H	\$116.75	\$146.25	_____	_____
8' L x 24" W x 42" H	\$114.75	\$143.50	_____	_____
8' L x 30" W x 42" H	\$138.00	\$172.25	_____	_____
4th Side Drape 30"	\$26.00	\$37.25	_____	_____
4th Side Drape 42"	\$26.00	\$37.25	_____	_____

Undraped Tables are 25% off of draped rate. (Circle size above)

- Please select color:**
- Burgundy
 - Blue
 - Teal
 - Black
 - Purple
 - Gray
 - Gold
 - Green
 - White

TABLETOP RISERS -12" w x 8" h (Covered in white plastic)

Description	Discount	Standard	Qty.	Total
4' Long, Single Step	\$44.50	\$62.25	_____	_____
6' Long, Single Step	\$50.00	\$70.00	_____	_____

Uncovered Risers are 25% off of the covered rate. (Circle size above)

DRAPES (Drape rates are per linear foot)

Description	Discount	Standard	Qty.	Total
8' Background Drape / lin. ft.	\$8.00	\$11.25	_____	_____
Side Rail Drape 42" h. / lin. ft.	\$5.00	\$7.00	_____	_____

- Please select color:**
 (For background drape & side rail only)
- Burgundy
 - Blue
 - Teal
 - Black
 - Purple
 - Gray
 - Gold
 - Green
 - White

ORDER TOTAL: \$ _____

YES, I have completed and enclosed the Authorization and Agreement to Terms and Conditions Form and I understand that all orders are subject to New York State Sales tax 8.125%.

Company Name: _____ Booth#: _____

STANDARD MODULAR EXHIBIT RENTAL ORDER FORM

Please Mail or Fax Completed Form to AEX Convention Services:
 3089 English Creek Ave., Egg Harbor Township, NJ 08234
 Fax: (609) 272-1680 • Phone: (609) 272-1600

Show Name: NY TACTICAL EXPO 2010

Show Dates: APRIL 27-28, 2010

Deadline Date To Receive Discounted Rates: APRIL 12, 2010

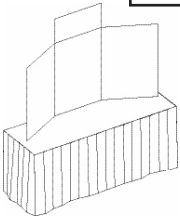
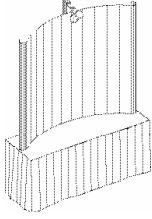
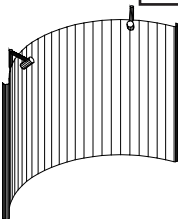
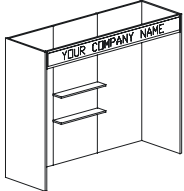
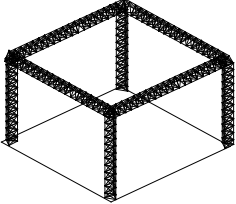
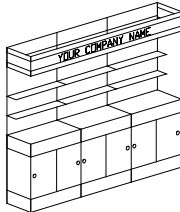
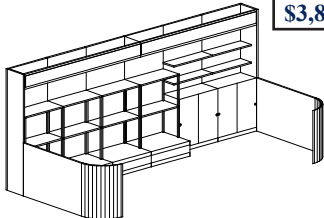
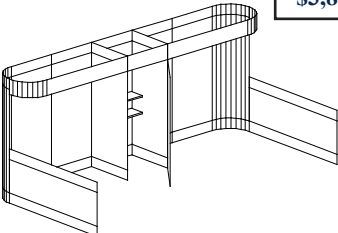
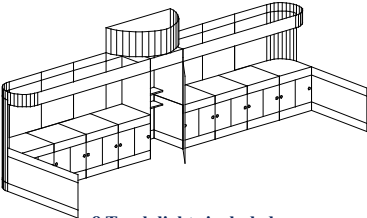
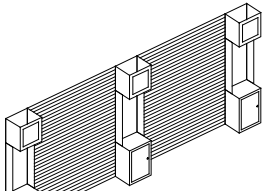
<p>(#1) Panel Tabletop</p> <p>\$398.00</p>  <p>60" wide x 36" high tabletop unit in silver. Velcro compatible</p>	<p>(#2) Curved Tabletop Pop-up</p> <p>\$525.25</p>  <p>68" wide x 64" high tabletop unit in silver. Velcro compatible with 1 spotlight</p>	<p>(#3) Pop-up Display</p> <p>\$1,104.00</p>  <p>10" wide x 8" compatible with 2 spotlights</p>	<p>(#4) 10' x 10' Hard wall Unit</p> <p>\$884.25</p>  <p>3 Track lights included</p>
<p>(#5) 20' x 20' Truss Unit</p> <p>\$4,669.25</p>  <p>Truss Exhibit available in various sizes</p>	<p>(#6) 10' x 10' Counter Exhibit</p> <p>\$2,175.50</p>  <p>3 Track lights included</p>	<p>(#7) 10' x 20' Shelf Unit</p> <p>\$3,873.50</p>  <p>6 Track lights included</p>	
<p>(#8) 10' x 20' Curved Exhibit</p> <p>\$3,873.50</p>  <p>6 Track lights included</p>	<p>(#9) 10' x 30' Curved Exhibit</p> <p>\$5,013.75</p>  <p>8 Track lights included</p>	<p>(#10) 10' x 20' Professional Exhibit</p> <p>\$4,669.25</p>  <p>3 Lights boxes, 3 Locking counters, Slatwall. Professionally Black Laminated</p>	

NOTE: Above prices include delivery, installation and removal. Please see our Furniture and Carpet Rental Order Forms if you would like to order carpet or furniture.

- ❖ **Additional Lights** Qty. _____ Light @ \$48.00 each = \$ _____
- ❖ **Additional Hardware Shelves** Qty. _____ Shelves @ \$36.50 each = \$ _____
- ❖ **Aluminum Slatwall Per Panel** Qty. _____ Slatwall @ \$111.75 each = \$ _____
- ❖ **Units 4, 6, 7, 8, & 9 are provided in white hard wall unless colored or Velcro compatible panels are ordered.**
- **Red** ○ **Blue** ○ **Black** Qty. _____ Colored panels @ \$41.50 each = \$ _____
- Qty. _____ Velcro panels @ \$73.00 each = \$ _____
- ❖ **Matching counters 42" H x 21" L x 40" W** Qty. _____ Counters @ \$128.25 each = \$ _____

❖ Please call to discuss your sign requirements and pricing. Standard signage is black letters on a white background.

PRINT SIGN TEXT ON A SEPARATE SHEET:

❖ If you require a Custom Exhibit Design not shown above, please call (609) 272-1600

❖ Electric service IS NOT included. Please make arrangements in advance with exhibit facility.

Company Name: _____ Booth#: _____
 Unit# _____ Unit Price \$ _____

Add 30% if ordered after deadline \$ _____

SUBTOTAL, MODULAR EXHIBIT RENTAL ORDER \$ _____

YES, I have completed and enclosed the Authorization and Agreement to Terms and Conditions Form and I understand that all orders are subject to New York State Sales tax 8.125%.

PERFBOARD/TACKBOARD RENTAL ORDER FORM

Please Mail or Fax Completed Form to AEX Convention Services:
 3089 English Creek Ave., Egg Harbor Township, NJ 08234
 Fax: (609) 272-1680 • Phone: (609) 272-1600

Show Name: NY TACTICAL EXPO 2010

Show Dates: APRIL 27-28, 2010

Deadline Date To Receive Discounted Rates: APRIL 12, 2010

GRID WALL

Each Panel is 2' x 8' with a 3" x 3" grid.
 At least two panels are needed to be free standing without the use of feet.
 Feet must be rented to have individual (2' x 8') free standing units.
 Feet are supplied attached to each free standing unit.

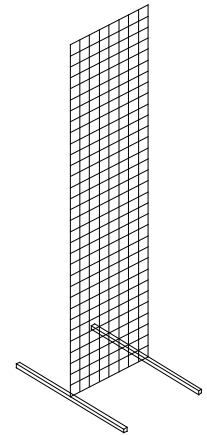
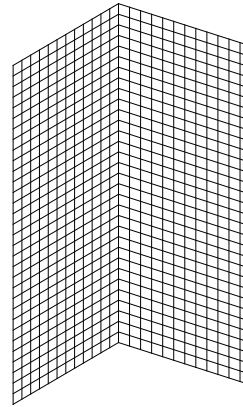

Description	Discount	Standard		Total
_____ 2' x 8'	\$73.25	\$102.50	each =	\$ _____
_____ Pair of feet	\$29.25	\$41.00	each =	\$ _____

WHITE PERF BOARD (Shown Below)

WHITE TACK BOARD

Description	Discount	Standard	Qty.	Total
Style A - 2' w x 8' h Panel	\$147.75	\$206.75	_____	\$ _____
Style A - 4' w x 8' h Panel	\$151.00	\$211.50	_____	\$ _____
Style B - 8' w x 2' h Panel	\$147.75	\$206.75	_____	\$ _____
Style B - 8' w x 4' h Panel	\$151.00	\$211.50	_____	\$ _____
Style C - 10' w x 8' h Panel	\$632.75	\$885.75	_____	\$ _____
Perf Board Shelving 4' long	\$34.75	\$48.75	_____	\$ _____

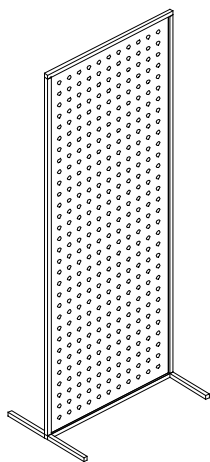

Style A
Vertical to Floor

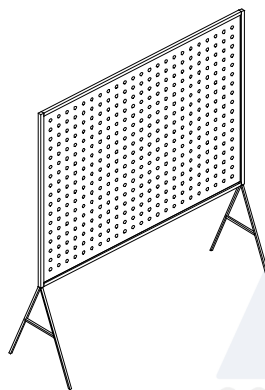

Style B
Horizontal off Floor
(30" Off the Floor)

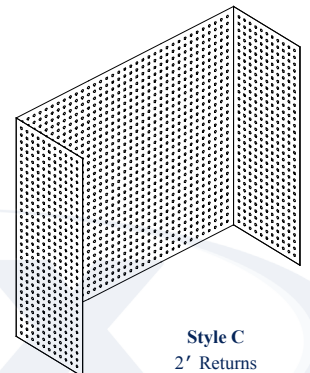

Style C
2' Returns

SUBTOTAL GRID WALL, PERF BOARD & TACK BOARD ORDER: \$ _____

YES, I have completed and enclosed the Authorization and Agreement to Terms and Conditions Form and I understand that all orders are subject to New York State Sales tax 8.125%.

Company Name: _____ Booth#: _____



SHOWCASE RENTAL ORDER FORM

Please Mail or Fax Completed Form to AEX Convention Services:
 3089 English Creek Ave., Egg Harbor Township, NJ 08234
 Fax: (609) 272-1680 • Phone: (609) 272-1600

Show Name: NY TACTICAL EXPO 2010

Show Dates: APRIL 27-28, 2010

Deadline Date To Receive Discounted Rates: APRIL 12, 2010

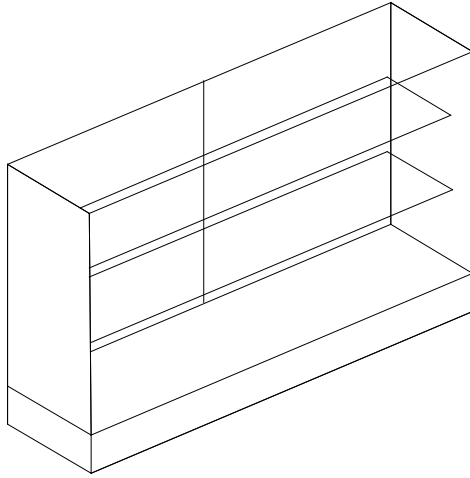

FULL VISION SHOWCASE

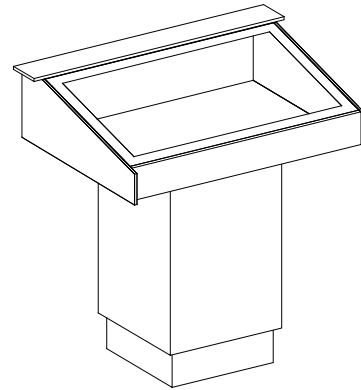

TOP VISION SHOW CASE

Glass shelves are used in these items. To prevent breakage of shelves and articles, good judgement must be used during installation and loading of glass shelves. Take care in placing heavy items or large quantities of items on these glass shelves. A sudden shock, even from small items dropped, can result in broken glass causing personal injury as well as loss of treasured valuables. AEX Convention Services does not assume responsibility for broken glass and/or personal valuables. Rental price includes delivery to and removal from your booth space.

PLEASE MAKE YOUR SELECTION BELOW

Type	Qty.	Discount	Standard	Total
Full Vision Showcase 38" H x 20" D x 70"	_____	\$418.25	\$585.50	_____
Top Vision Showcase 49" H x 39" D x 43"	_____	\$371.50	\$520.00	_____
Additional Shelves	_____	\$27.00	\$37.75	_____
Locks	_____	\$25.00	\$35.00	_____

Electrical Orders must be placed with the **ELECTRICAL SERVICE FORM**

ALL ORDERS ARE SUBJECT TO AVAILABILITY.
 ADDITIONAL CASES AVAILABLE UPON REQUEST, PLEASE CALL.



SUBTOTAL SHOWCASE RENTAL ORDER: \$ _____

YES, I have completed and enclosed the Authorization and Agreement to Terms and Conditions Form and I understand that all orders are subject to New York State Sales tax 8.125%.

Company Name: _____ Booth#: _____



MATERIAL HANDLING ORDER FORM

Please Mail or Fax Completed Form to AEX Convention Services:
 3089 English Creek Ave., Egg Harbor Township, NJ 08234
 Fax: (609) 272-1680 • Phone: (609) 272-1600

Show Name: NY TACTICAL EXPO 2010

Show Dates: APRIL 27-28, 2010

Deadline Date To Receive Discounted Rates: APRIL 12, 2010

MATERIAL HANDLING RATES - ROUND-TRIP RATES, PER SHIPMENT, USE INCOMING WEIGHT ONLY AND ROUND UP TO THE NEXT 100 LBS. THESE RATES ARE SUBJECT TO SURCHARGE (See Below).

SHIPMENTS RECEIVED WITHOUT BILLS OF LADING, SUCH AS DHL, UPS OR FED EX WILL BE DELIVERED TO THE BOOTH WITHOUT GUARANTEE OF PIECE COUNT OR CONDITION.

CERTIFIED WEIGHT TICKETS ARE REQUIRED FOR EACH SHIPMENT, IF NOT PROVIDED, YOU AGREE TO USE AEX CONVENTION SERVICES' ESTIMATED WEIGHTS.

RATE PER 100 LBS. (200 L.B. MIN.)

(CWT - 100 lbs.)

Description	Receiving	S.T. In / S.T. Out	Overtime In or Out	O.T. In / O.T. Out
A1 - ON TIME Crated or Skidded shipments (LTL Carriers with established local terminals)	Advance Warehouse	\$61.50 per cwt. \$123.00 minimum	\$92.25 per cwt. \$184.50 minimum	\$123.00 per cwt. \$246.00 minimum
A2 - VAN LINES (Irregular route carrier)	Advance Warehouse	\$83.25 per cwt. \$166.50 minimum	\$124.75 per cwt. \$249.50 minimum	\$166.50 per cwt. \$333.00 minimum
B1 - ON TIME Crated or Skidded shipments (LTL Carriers with established local terminals)	Convention Site	\$61.50 per cwt. \$123.00 minimum	\$92.25 per cwt. \$184.50 minimum	\$123.00 per cwt. \$246.00 minimum
B2 - VAN LINES and loose and uncrated shipments (Irregular route carrier)	Convention Site	\$83.25 per cwt. \$166.50 minimum	\$124.75 per cwt. \$249.50 minimum	\$166.50 per cwt. \$333.00 minimum
C* - Small Package (Cartons or envelopes-Includes delivery from DHL, UPS or Fed Ex. Max. weight is 50lbs. per shipment.	Convention Site		First carton \$44.50 Each additional carton \$13.25	

*Cartons and envelopes received will be delivered without piece count or condition. Maximum weight is 50 lbs. per shipment, per delivery. Includes UPS, DHL and Fed Ex shipments. All shipments received via air carrier that do not fall into the small package category may be subject to special handling charges.

(S.T. = Straight Time / O.T. =Overtime)

A Transfer fee of \$125.00 + \$12.00 per cwt. will apply for all shipments going to AEX Convention Service's Warehouse to be pick-up by outside carriers.

This fee of \$125.00 will apply for all shipments going to AEX Convention Services Warehouse to be shipped via UPS (AEX's account only)

Overtime Rates will apply if: • Inbound vehicles arrive at the dock weekdays prior to 8:00 AM or after 3:00 PM or anytime Saturday, Sunday and Holidays

• Outbound vehicles are loaded weekdays prior to 8:00 AM or after 3:00 PM or anytime Saturday, Sunday and Holidays.

• Warehouse freight is moved to the event floor on overtime due to scheduling.

A 50% surcharge will apply if: freight is received after the "last day accepted" for Advance warehouse shipments or outside indicated times to the convention site.

Estimated charges for material handling lbs. x per cwt. = \$
Estimated Weight Estimated Rate Total Estimated Material Handling

SUBTOTAL MATERIAL HANDLING ORDER: \$ _____

YES, I have completed and enclosed the Authorization and Agreement to Terms and Conditions Form and I understand that all orders are subject to New York State Sales tax 8.125%.



ADVANCE WAREHOUSE SHIPPING

Show Name: NY TACTICAL EXPO 2010

Show Dates: APRIL 27-28, 2010

Deadline Date To Receive Discounted Rates: APRIL 12, 2010

ADVANCE WAREHOUSE SHIPPING

TRADE SHOW SHIPMENT - PLEASE EXPEDITE

Show Name: (NY TACTICAL EXPO 2010)

To: _____
Name of Exhibitor

Booth#: _____

**AEX CONVENTION SERVICES
C/O WAREHOUSE MANAGER
6990 NORTHERN BLVD.
EAST SYRACUSE, NY 13057**

Deliver BEFORE April 19, 2010

EXHIBIT MATERIAL

Please Make additional copies of label for each piece shipped.

Receiving 8AM-3PM, Monday-Friday
Check In By 3PM



DIRECT SHIPMENT

Please Mail or Fax Completed Form to AEX Convention Services:
3089 English Creek Ave., Egg Harbor Township, NJ 08234
Fax: (609) 272-1680 • Phone: (609) 272-1600

Show Name: NY TACTICAL EXPO 2010

Show Dates: APRIL 27-28, 2010

Deadline Date To Receive Discounted Rates: APRIL 12, 2010

DIRECT SHIPMENT TO THE CONVENTION CENTER

TRADE SHOW SHIPMENT - PLEASE EXPEDITE

Show Name: NY TACTICAL EXPO 2010

To: _____
Name of Exhibitor

Booth#: _____

**TURNING STONE RESORT & CASINO
C/O AEX CONVENTION SERVICES
5218 PATRICK ROAD
VERONA, NY 13478**

Deliver ON APRIL 26, 2010 between 8:30 AM - 5:00 PM
and ON APRIL 27, 2010 between 7:00 AM - 9:30 AM

EXHIBIT MATERIAL

Please Make additional copies of label for each piece shipped.



LABOR SERVICE FORM

Please Mail or Fax Completed Form to AEX Convention Services:
 3089 English Creek Ave., Egg Harbor Township, NJ 08234
 Fax: (609) 272-1680 • Phone: (609) 272-1600

Show Name: NY TACTICAL EXPO 2010

Show Dates: APRIL 27-28, 2010

Deadline Date To Receive Discounted Rates: APRIL 12, 2010

PLAN A: PROFESSIONALLY SUPERVISED INSTALLATION AND DISMANTLING (see next page for important information)
LET US DO THE WORK FOR YOU - YOU WALK AWAY!

- Supervision by our professionals
- Installation and dismantling by experienced laborers
- Materials prepared for shipment to next destination
- Empties stored during event
- Shipping labels provided

Please forward detailed instructions, blueprints or photos and complete the information on the back of this form. Our cost for this service is 35% of your total labor bill (\$35.00 minimum). This service provides our expert supervision and saves the expense and productive time of your own personnel. Please note: Our liability for damages, for whatever reason, is limited to our billed cost for supervision.

PLAN B: EXHIBITOR'S SUPERVISION

- Installation and dismantling by experienced laborers
- Empties stored during event

For those using Plan B, on the day and time that you have requested labor, please report to the AEX Convention Services Desk to pick-up and sign out your labor crew. You will be charged a one hour minimum per laborer ordered if you do not report to the Service Desk at the time you have requested labor. The labor crew will not be sent to your booth without being signed out. Upon completion of their work, you are required to accompany the laborers back to the AEX Convention Services Desk and sign them in. All exhibitors ordering labor will be billed a one-hour minimum for each person ordered unless a written cancellation order is received by 11:00 am the day before the labor is supplied. It is not necessary to order labor for unloading freight (see Material Handling Order Form). ALL WORK IS DONE ONLY UNDER THE SUPERVISION OF THE EXHIBITOR'S REPRESENTATIVE.

LABOR RATES: 1 HOUR MINIMUM PER PERSON, 1 HOUR INCREMENTS THEREAFTER
PLEASE NOTE: LIGHTS, ELECTRIC MOTORS AND OTHER ELECTRICAL COMPONENTS REQUIRE THE USE OF ELECTRICIAN LABOR. IF NECESSARY, YOU WILL BE CHARGED ACCORDINGLY.

	Discount	Standard
<u>Straight Time</u> (Monday through Friday between 8 am - 4:30 pm)	\$72.50 per hour	\$101.50 per hour
<u>Overtime</u> (Monday through Friday before 8 am and after 4:30 pm and anytime Saturday or Sunday)	\$121.50 per hour	\$170.50 per hour
<u>Double Time</u> (Anytime on Holidays)	\$144.50 per hour	\$202.75 per hour

Starting time can be guaranteed only in those instances where workers are requested for the start of published move-in times (usually 8:00 am). Please indicate service desired by checking either Plan A or Plan B. If no plan is indicated, labor cannot be assigned until exhibitor's representative reports to the service desk.

	Estimated Hours	Start Date	Start Time	Estimated Finished Time	# of Laborers	Rate	AEX Supervision	Estimated Total Cost
Installation								
Dismantle								

Dismantle - you will be charged for the same estimated hours and number of laborers for dismantle. In the event less chargeable time is used, we will credit you following the close of the show. All labor provided at show site but note ordered in advance will be charged at the standard rate.

SUBTOTAL ESTIMATED LABOR SERVICE ORDER: \$ _____

YES, I have completed and enclosed the Authorization and Agreement to Terms and Conditions Form and I understand that all orders are subject to New York State Sales tax 8.125%.

Company Name: _____ **Booth#:** _____



SUPERVISED INSTALLATION AND DISMANTLE INFORMATION SHEET

Please Mail or Fax Completed Form to AEX Convention Services:
3089 English Creek Ave., Egg Harbor Township, NJ 08234
Fax: (609) 272-1680 • Phone: (609) 272-1600

Show Name: NY TACTICAL EXPO 2010

Show Dates: APRIL 27-28, 2010

Deadline Date To Receive Discounted Rates: APRIL 12, 2010

Print Your Company Name: _____

Booth# _____

COMPLETE THIS FORM ONLY IF YOU HAVE SELECTED Plan A: Professionally Supervised Installation and Dismantle

This information is required in order to ensure proper supervision and installation of your display.

Freight is arriving at Warehouse Show Site Loading Dock

Date Shipped: _____ Via: _____ (freight carrier)

Display shipped from: _____ (address)

of Crates: _____ # of Cartons: _____ Estimated Weight: _____

Display Includes: _____

Booth carpet in shipment? Yes No

Set-up instructions: Attached to this order With display

RETURN SHIPPING:

Return Display to the following address:

Via: _____ (carrier)

EMERGENCY CONTACT AT SHOW SITE:

Name: _____ Arrival Date: _____

Hotel: _____ Telephone: _____

YES, I have completed and enclosed the Authorization and Agreement to Terms and Conditions Form and I understand that all orders are subject to New York State Sales tax 8.125%.

Company Name: _____ **Booth#:** _____



TURNING STONE RESORT & CASINO

Trade shows and events held in Turning Stone Resort & Casino are subject to union jurisdictions that affect exhibitors. You will find the jurisdictions are comparable, and in many cases more user friendly, to other union facilities. This outline is designed to assist you by answering the most frequently asked questions.

Freight & Material Handling

You may ship goods, via the carrier of your choice, to either the advance warehouse or direct to show site for arrival during the published receiving periods. Material Handling (drayage) is within the Decorator's Union jurisdiction (unload, deliver, remove, and reload freight). Material Handling may be ordered using the "Material Handling Order Form" provided in the kit and is entirely distinct from shipping. Exhibitors may handle freight at show site that arrives via their Personally Owned Vehicle (no rental or company vehicle), provided such vehicle is no larger than a 4' x 4', minivan or station wagon, and the freight is hand carried (no dollies, hand trucks, or other wheeled vehicle) to and from your booth.

Furniture & Carpet

Furniture and carpet may be rented using the "Furniture Rental Order Form" and the "Carpet Rental Order Form" which are provided in the kit. The price includes union labor for delivery, installation, and removal.

Booth Erection & Dismantling

Exhibitors may, at their option, erect and dismantle their own booths using their own full-time employees. If their own employees are not available, labor can be ordered using the "Labor Order Form" in the kit. Rigging crews may be hired to move large machinery within booths and can be ordered using the "Forklift & Rigging Crew Order Form" provided in the kit.

Tipping

AEX Convention Services requests that exhibitors do not tip our employees. They are paid an excellent wage scale denoting a professional status, and tipping is not necessary. This applies to all AEX Convention Services employees and its subcontractors.

Safety

Standing on chairs, tables or other rental furniture is prohibited. The furniture is not engineered to support your standing weight. AEX Convention Services is not responsible for injuries caused by improper use of this furniture.

Please assist in our efforts to provide a safe working environment for everyone. If you would like additional information or how the jurisdictions may apply to you and your exhibit, please call AEX Convention Services at (609) 272-1600 for assistance.





CLEANING SERVICE ORDER FORM

Please Mail or Fax Completed Form to: AEX Convention Services
3089 English Creek Ave., Egg Harbor Township, NJ 08234
Fax: (609) 272-1680 • Phone: (609) 272-1600
www.aexservices.com

Show Name: NY TACTICAL EXPO 2010

Show Dates: APRIL 27-28, 2010

Deadline Date To Receive Discounted Rates: APRIL 12, 2010

USE THIS FORM TO ORDER CLEANING SERVICE WITHIN YOUR BOOTH SPACE AND FOR DEBRIS ACCUMULATED DURING SET-UP AND EXHIBIT HOURS.

All rental carpets ordered from AEX Convention Services are installed in clean condition.

VACUUMING / SHAMPOO

All rates are based on the total square footage of your exhibit space (100 sq. ft. minimum)

Please check preference below:

		Discount	Standard
<input type="radio"/>	One Time Vacuum carpet before initial opening of event	\$.38/sq. ft.	\$.52/sq. ft.
<input type="radio"/>	Daily Vacuum carpet before initial opening of event and daily thereafter over 1,000 Ft.	\$.32/sq. ft./day	\$.43/sq. ft./day
<input type="radio"/>	Shampoo Shampoo carpet once (specify day _____)	\$.28/sq. ft./day	\$.38/sq. ft./day
		\$.44/sq. ft./day	\$.60/sq. ft./day

Exhibit Space: _____ ft (x) _____ ft = _____ sq. ft. (x) \$ _____ (x) _____ = \$ _____
(100 sq. ft. minimum) rate per sq. ft. Days Total

PORTER SERVICE

	Discount	Standard
Empty wastebasket, tidy and spot clean exhibit space at two hour intervals during show hours.	\$128.50	\$180.00

Please check preference below:

Daily Once (Specify Day) _____ Date: _____

Porter Service: _____ days (x) amount per day \$ _____

SUBTOTAL ESTIMATED CLEANING ORDER: \$ _____

YES, I have completed and enclosed the Authorization and Agreement to Terms and Conditions Form and I understand that all orders are subject to New York State Sales tax 8.125%.

Company Name: _____ Booth#: _____



EAC/Third Party Billing

Please Mail or Fax Completed Form to AEX Convention Services:
 3089 English Creek Ave., Egg Harbor Township, NJ 08234
 Fax: (609) 272-1680 • Phone: (609) 272-1600

Show Name: NY TACTICAL EXPO 2010

Show Dates: APRIL 27-28, 2010

Deadline Date To Receive Discounted Rates: APRIL 12, 2010

To: AEX Services

Please be advised that we will be using an independent contractor of our own choosing to perform installation/dismantle labor services at the TURNING STONE RESORT & CASINO. We are aware that a responsible representative of our contractor must report to the AEX Service Desk on the first day of set-up. No badges will be issued until all pertinent paperwork is in order.

Third Party/Display House:

Address: _____
 City : _____ State: _____ Zip: _____
 Contact: _____
 Phone Number: _____ Booth Number: _____
 Your Name: _____ Your Signature: _____
 Date: _____

Display house must also provide a Certificate of Insurance to AEX

	Exhibitor will pay	Third Party will pay	
Furniture	<input type="radio"/>	<input type="radio"/>	\$ _____
Carpet	<input type="radio"/>	<input type="radio"/>	\$ _____
Labor	<input type="radio"/>	<input type="radio"/>	\$ _____
Cleaning	<input type="radio"/>	<input type="radio"/>	\$ _____
Freight	<input type="radio"/>	<input type="radio"/>	\$ _____
Utilities	<input type="radio"/>	<input type="radio"/>	\$ _____
Other Services	<input type="radio"/>	<input type="radio"/>	\$ _____

Acceptance of this third party billing is contingent upon:

An Authorization Form, the Insurance Form and return of the notification letter prior to the deadline date.

Company Name: _____ **Booth#:** _____



GRAPHICS ORDER FORM

Please Mail or Fax Completed Form to AEX Convention Services:
 3089 English Creek Ave., Egg Harbor Township, NJ 08234
 Fax: (609) 272-1680 • Phone: (609) 272-1600

Show Name: NY TACTICAL EXPO 2010

Show Dates: APRIL 27-28, 2010

Deadline Date To Receive Discounted Rates: APRIL 12, 2010

Our Experienced Team is committed to providing accurate and professional trade show graphics using the most advanced equipment available.

Trade Show Booth Panels • Banners • Backlits • Posters Signage • POP Displays • Table Drapes • Floor Graphics

Full-Service Graphic Production

Looking for trade show graphics that will get you noticed? Why ship graphic materials to your show? We have full service graphic production capabilities that can meet your design and production needs and deliver the final product right to your booth! We'd be glad to take your graphic order and make it quick, make it easy and, of course, make it big!

For more information call AEX Exhibitor Services at 609-272-1600.

I AM SUPPLYING MY OWN ART ON DISK I NEED ITEMS DESIGNED. SEE COPY AND LAYOUT SPECS BELOW.

FULL COLOR DIGITAL POSTERS AND COUNTER CARDS

Description	Discount	Standard	Qty.	Total
7" x 11" Counter Card	\$15.50	\$31.25	_____	_____
7" x 44" Counter Card	\$26.00	\$52.00	_____	_____
11" x 14" Counter Card	\$33.50	\$66.50	_____	_____
9" x 44" Poster	\$48.25	\$67.25	_____	_____
14" x 22" Poster	\$41.50	\$83.25	_____	_____
14" x 44" Poster	\$48.00	\$95.50	_____	_____
22" x 28" Poster	\$62.50	\$104.00	_____	_____
26" x 95" Poster on Foamcore	\$177.50	\$248.25	_____	_____
28" x 44" Poster	\$93.50	\$156.00	_____	_____
Easel Back for Counter Card	\$8.75	\$12.25	_____	_____

FULL COLOR DIGITAL BANNERS

Description	Discount	Standard	Qty.	Total
3' x 6'	\$233.50	\$327.25	_____	_____
3' x 8'	\$265.25	\$371.25	_____	_____
4' x 8'	\$297.25	\$416.50	_____	_____
Grommets	\$5.50	\$8.00	_____	_____
Pole Pockets	\$16.00	\$22.75	_____	_____

COPY AND LAYOUT SPECIFICATIONS

Indicate: _____ Vertical or _____ Horizontal (Please attach a layout to this for if necessary)

Include e-mail address of proofing is required: _____

(Please note: Deadline for requesting a proof is 10 days prior to the first day of installation)

SUBTOTAL SHOWCASE RENTAL ORDER: \$ _____

YES, I have completed and enclosed the Authorization and Agreement to Terms and Conditions Form and I understand that all orders are subject to New York State Sales tax 8.125%.

Company Name: _____ **Booth#:** _____

AEX maintains a fully-equipped graphics shop that offers: Graphic Design, Large Format Printing, Backlit Graphics, Lamination, Vinyl Graphics, Vinyl Banners. For custom work and quotation, please call Exhibitor Services at 609-272-1600.



FLORAL RENTAL ORDER FORM

Please Mail or Fax Completed Form to AEX Convention Services:
 3089 English Creek Ave., Egg Harbor Township, NJ 08234
 Fax: (609) 272-1680 • Phone: (609) 272-1600

Show Name: NY TACTICAL EXPO 2010

Show Dates: APRIL 27-28, 2010

Deadline Date To Receive Discounted Rates: APRIL 12, 2010

SHOW SPECIAL \$150.00

Two 5' Green Plants and fresh floral centerpiece of seasonal flowers
 (Must be ordered by deadline date)

Blooming Potted Plants - Indicate Color Selection

Description	Discount	Standard	Qty.	Total
Azaleas - Available in season	\$39.25	\$55.00	_____	_____
Chrysanthemums - White/Yellow/Bronze/Purple	\$28.50	\$40.00	_____	_____
Other Flowering Plants - Please specify _____	\$40.00	\$56.00	_____	_____

Tropical Green Plants - Indicate Size and Selection

Description	Discount	Standard	Qty.	Total
Ferns - Floor/Hanging	\$40.50	\$56.75	_____	_____
3 Ft. - Slim or Full	\$50.50	\$70.75	_____	_____
4 Ft. - Slim or Full	\$61.75	\$86.50	_____	_____
5 Ft. - Slim or Full	\$83.75	\$117.25	_____	_____
6 Ft. - Slim or Full	\$94.25	\$132.00	_____	_____
7 Ft. - Slim or Full	\$100.50	\$140.75	_____	_____

Flower Arrangements - Indicate Color, Style and Price

Description	Discount	Standard	Qty.	Total
Arrange in Wicker Basket	\$55.75	\$78.00	_____	_____
Vase Arrangement	\$55.75	\$78.00	_____	_____
Centerpiece (Tall, low one side)	\$61.75	\$86.50	_____	_____
Exotic Arrangement (Birds of Paradise, Anthurim, etc.)	\$67.00	\$93.75	_____	_____

Rose Arrangements - Indicate Color, Style and Price

Description	Discount	Standard	Qty.	Total
Color: _____	\$84.00	\$117.50	_____	_____

Balloons

Description	Discount	Standard	Qty.	Total
Mylar Balloons - Indicate Style _____	\$5.75	\$8.50	_____	_____
Latex Balloons - Indicate Color _____	\$3.25	\$4.75	_____	_____

To ensure your floral request, please order no later than 4 days prior to show opening. Orders after that time will be on available basis only.

Due to the seasonal nature of flowers, please indicate your phone number and contact person so that we may confirm your order and let you know what is in season.

Note: Exhibitors are responsible, up to one hour after the published closing time of the show, for safeguarding all rented plants, containers and materials until picked up by a floral representative. Missing material shall be billed to the exhibitor at twice the standard rental fee.

Phone: (____) _____ **Contact:** _____

SUBTOTAL FLORAL RENTAL ORDER: \$ _____

YES, I have completed and enclosed the Authorization and Agreement to Terms and Conditions Form and I understand that all orders are subject to New York State Sales tax 8.125%.

Company Name: _____ **Booth#:** _____